



BARIQ Valves Manufacturer
مصنع صمامات بارق للصناعة

VISION رؤية
2030
المملكة العربية السعودية
KINGDOM OF SAUDI ARABIA



BARIQ Pressure Independent Control Valve (PICV) MODEL BRQ-9000 SF

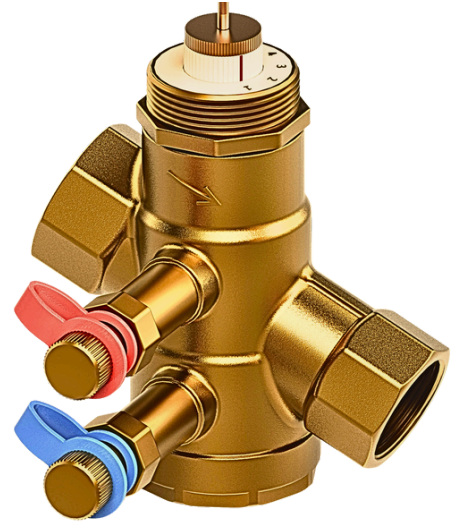

Manufacturing Standard

- Design and manufacture in accordance with Forged and cast brass material specification EN 12165 / EN 1982
- Pressure testing and leakage classification EN 12266-1 / ISO 5208
- Flow calibration testing ISO 6788
- Wall thickness and pressure design requirements EN 12516-1
- Face-to-face dimensions EN 558 / ISO 5752

Technical Overview

- Pressure rating: PN25
- Max working pressure: 25 bar
- Temperature range: -10°C to 110°C
- Connection type: Threaded (compliant with BS EN 10226)
- maximum operating pressure differential ≤ 400 Kpa
- Replaceable seats with tight shut-off capability
- Control precision $\pm 5\%$
- Leakage rate Class $< Kvs \times 0.05\%$ Class IV

Product Description

The BRQ 9000SF is a high-performance Pressure Independent Control Valve (PICV) designed for precise flow regulation in HVAC systems. It ensures accurate hydronic balancing, regardless of fluctuations in system pressure. This valve combines the functions of a control valve, a differential pressure regulator, and a balancing valve in a single compact unit.

Medium

Chilled Water	For cooling systems
Hot Water	For heating systems (within temperature limits)
Glycol-Water Mixture	Up to 50% glycol





BRQ-9000SF MATERIAL AND DIMENSIONS

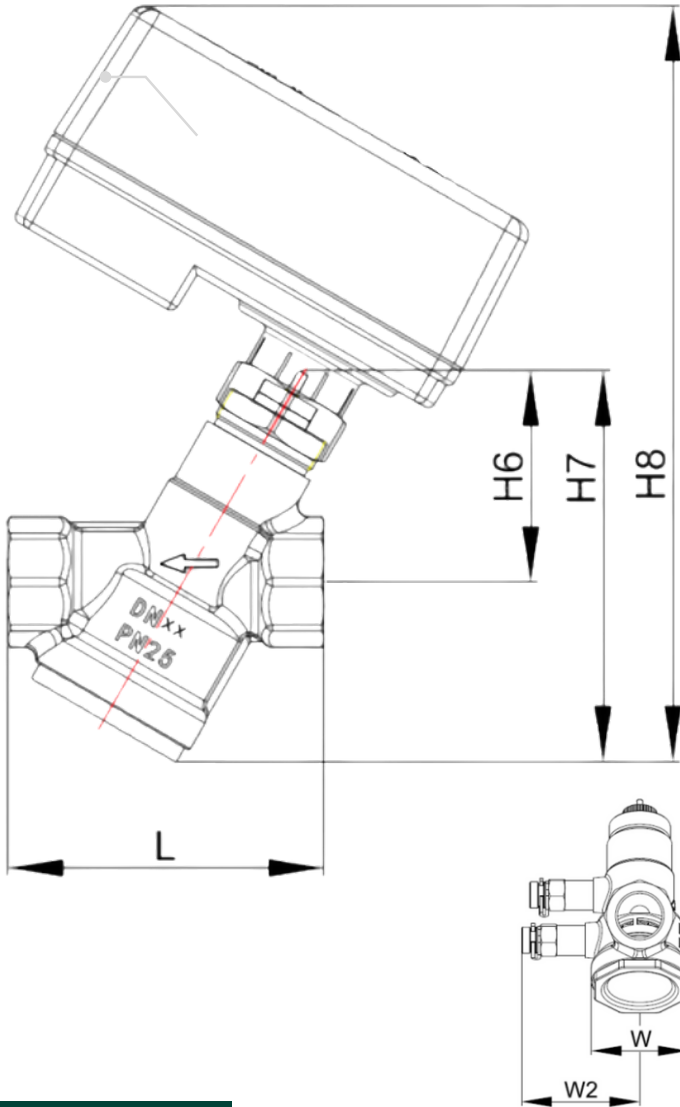

Material Specification	
Component	Material / Spec
Valve body	DZR Brass CW602N
Stem	Stainless steel
Trim (plug/seat/internal parts)	Brass, Stainless steel, PPS
Seals (O-rings)	EPDM
Spring	Stainless steel
Pressure class	PN25 (per ISO 7268)
Medium temperature range	1...110 °C
Pipe connection	Internal thread BSP (ISO 7/1)
Pressure test plugs	G 1/4" self-sealing test points

Dimensions

DN	L (mm)	W (mm)	W2 (mm)	H6 (mm)	H7 (mm)	H8 (mm)	Weight (kg)	Stroke (mm)
15	75	45	57	52	101	199	0.65	2.5
20	85	48	59	57	105	203	0.72	2.5
25	90	48	59	62	114	212	0.98	5
32	115	59	65	75	138	236	1.35	6



BRQ-9000 SF Technical data

Technical Information

Parameter	Value
Size Range	DN15 , DN20 , DN25 , DN32
Design Pressure	2500 kPa (PN25).
Max Working Pressure	25 bar
Temperature Range	-10°C to 110°C
Connection Type	Internal thread BSP (ISO 7/1)
Leakage Rate	<Kvs×0.05% Class IV
Stroke	<ul style="list-style-type: none"> For sizes DN15–DN20: Stroke length 2.5 mm For sizes DN25: Stroke length 5 mm For sizes DN32: Stroke length 6 mm
Body Material	DZR Brass CW602N
Internal Parts	Stainless steel / Brass / Teflon®
Compliance	EN 12266
Actuation Type	/ Manual / Motorized .1 -Compatible with BRQ ACT-13 actuator
Maintenance	Maintenance-free design

Flow Data

Size DN	PN	Qmin (L/h)	Qmax (L/h)	Δp range [kPa]	Kvs value
15	25	180	600	25..400	0.60
20	25	300	1000	30..400	1.00
25	25	340	1700	30..400	1.70
32	25	1100	3600	30..400	3.60

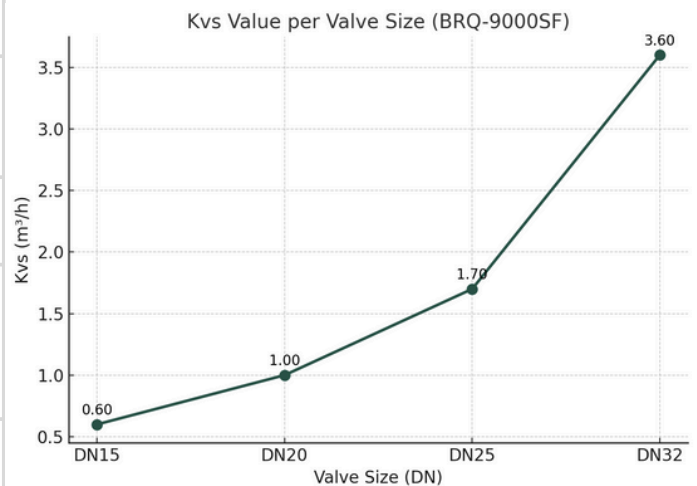

Operating ΔP Range: 25 - 400 kPa (0.25 - 4 bar)



BRQ-9000 SF Technical data

Flow VS Minimum differential pressure

BRQ-9000SF DN 15

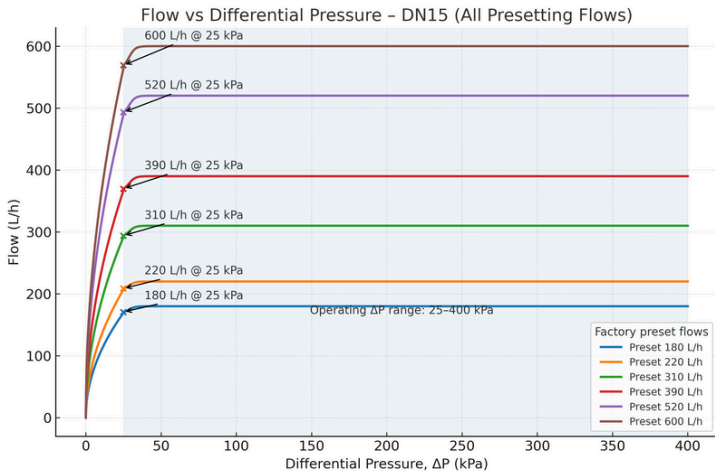

BRQ-9000SF DN 20

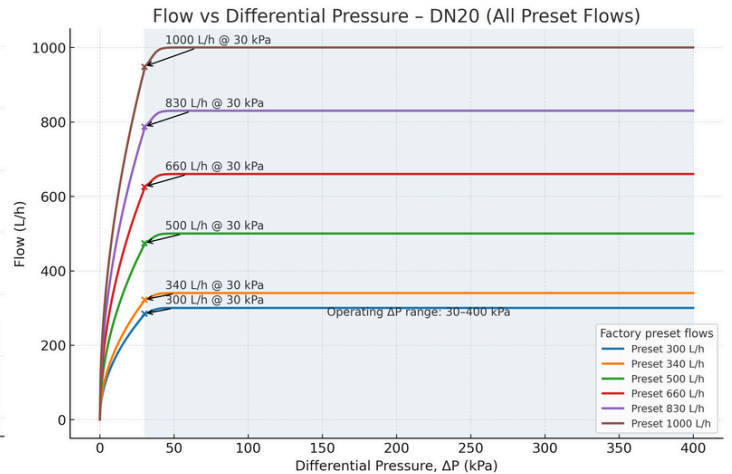

BRQ-9000SF DN 25

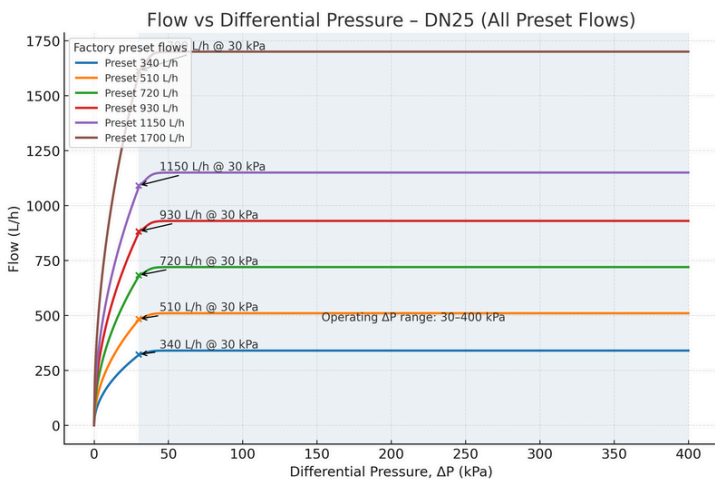

BRQ-9000SF DN 32

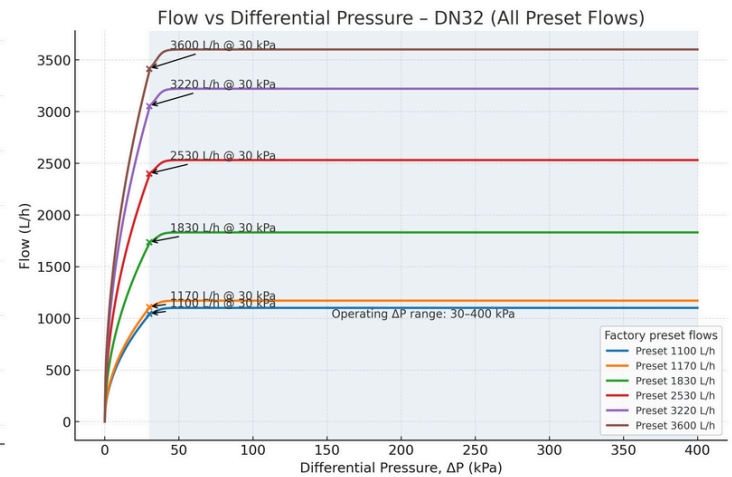

Operating Principle within ΔP Range

When the differential pressure across the valve (P1-P3) rises above the minimum value (ΔP_{min}), the integrated differential pressure controller becomes active. In this operating range, the valve maintains a constant flow rate, independent of system pressure variations, ensuring stable hydronic performance.

If the pressure drop falls below ΔP_{min} , the valve no longer regulates flow accurately and behaves as a static balancing valve. At higher differential pressures (up to ΔP_{max}), the valve continues to maintain constant flow within its specified tolerance, with minor hysteresis effects at the upper range.

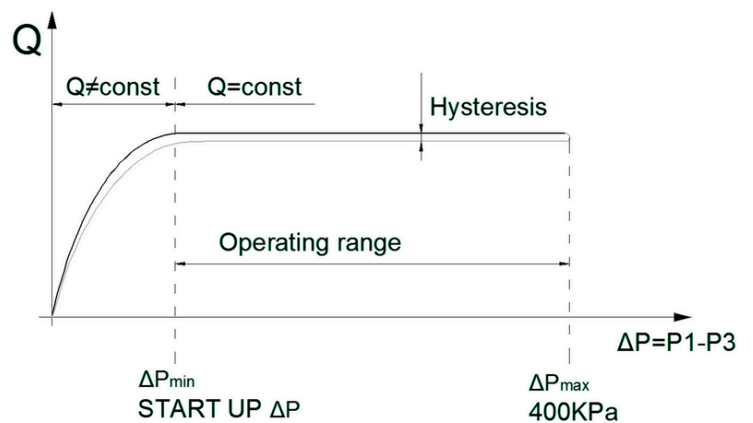



BRQ 9000 Technical data

BRQ 9000 PICV Presetting Table

• Note:

The presetting flow rates are based on the minimum differential pressure requirement (25–30 kPa depending on valve size). Actual flow may vary slightly depending on installation and site conditions. Ensure that the available differential pressure is within the operating range (25–400 kPa) to maintain stable and accurate control.

Preset	DN15 ($\Delta P_{min}=25$ kPa) l/h	DN20 ($\Delta P_{min}=30$ kPa) l/h	DN25 ($\Delta P_{min}=30$ kPa) l/h	DN32 ($\Delta P_{min}=30$ kPa) l/h
1.5	180	300	340	1100
2	220	340	510	1170
4	310	500	720	1830
6	390	660	930	2530
8	520	830	1150	3220
10	600	1000	1700	3600

Sizing Method

The required volumetric flow rate for selecting the PICV can be determined based on the heat demand and the temperature difference between supply and return water.

1. Determine heat demand (Rv) [kW]
2. Determine temperature difference (ΔT) [°C]
3. Calculate volumetric flow (Q):

$$Q \text{ [m}^3\text{/h]} = Rv \text{ [kW]} / (1.16 \times \Delta T \text{ [}^\circ\text{C]})$$

Where:

- Rv = Heat demand [kW]
- ΔT = Temperature difference between supply and return [°C]
- 1.16 = Constant (specific heat capacity and density of water)

Example

- Heat demand: Rv = 200 kW
- Temperature difference: $\Delta T = 6$ °C
- $Q = 200 / (1.16 \times 6) = 28.74 \text{ m}^3\text{/h}$

Selection Guideline

- PICV should be selected to operate at approximately 80% of its maximum flow rate to allow spare capacity for variations in system load.

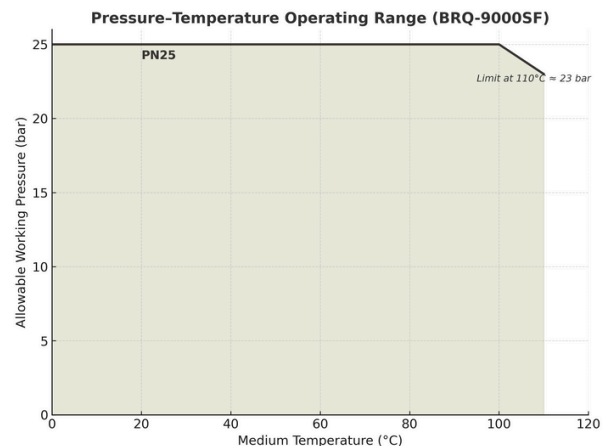
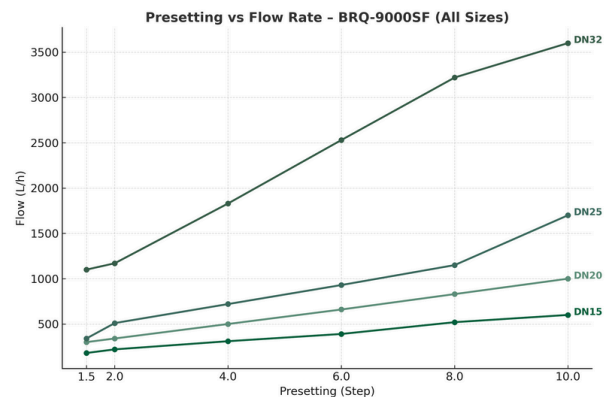



BRQ-9000 SF Technical data

Pressure Drop vs Flow Rate

The pressure drop across a Pressure Independent Control Valve (PICV) is directly related to the flow rate delivered through the valve. At a given preset, the relationship follows a quadratic law ($\Delta P \propto Q^2$), meaning that as flow increases, the required differential pressure rises with the square of the flow ratio.

- At maximum preset flow (Q_{max}), the valve requires at least the minimum differential pressure (ΔP_{min}) to maintain pressure-independent operation.
- Below this threshold, the valve cannot sustain the preset flow accurately.
- Once $\Delta P \geq \Delta P_{min}$, the PICV maintains the preset flow constant, independent of further increases in differential pressure, ensuring stable system performance.

This characteristic curve (Pressure Drop vs Flow Rate) provides the consultant with a clear indication of the hydraulic requirement for each valve size:

- DN15: $Q_{max} = 600$ L/h at $\Delta P_{min} = 25$ kPa
- DN20: $Q_{max} = 1000$ L/h at $\Delta P_{min} = 30$ kPa
- DN25: $Q_{max} = 1700$ L/h at $\Delta P_{min} = 30$ kPa
- DN32: $Q_{max} = 3600$ L/h at $\Delta P_{min} = 30$ kPa

By presenting these curves, the datasheet demonstrates how the BRQ-9000SF PICV ensures precise flow control while minimizing energy consumption and maintaining stable system balance.

BRQ-9000SF DN 15

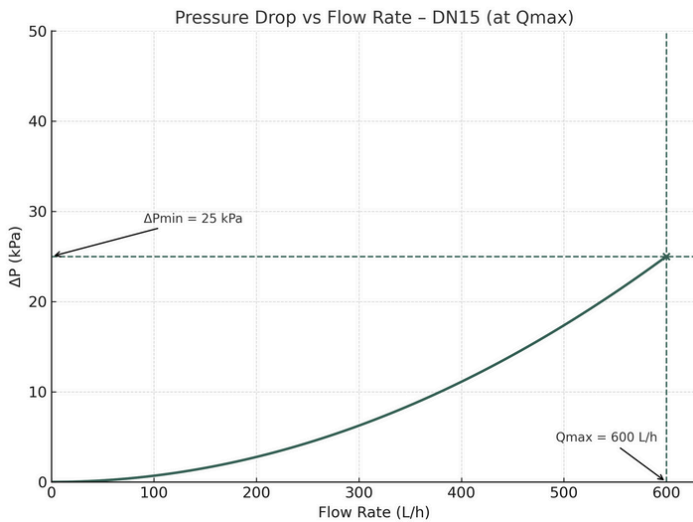

BRQ-9000SF DN 20

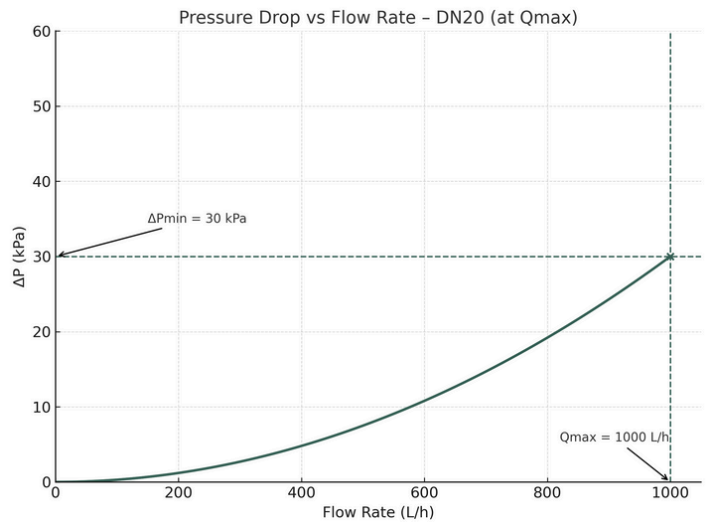

BRQ-9000SF DN 25

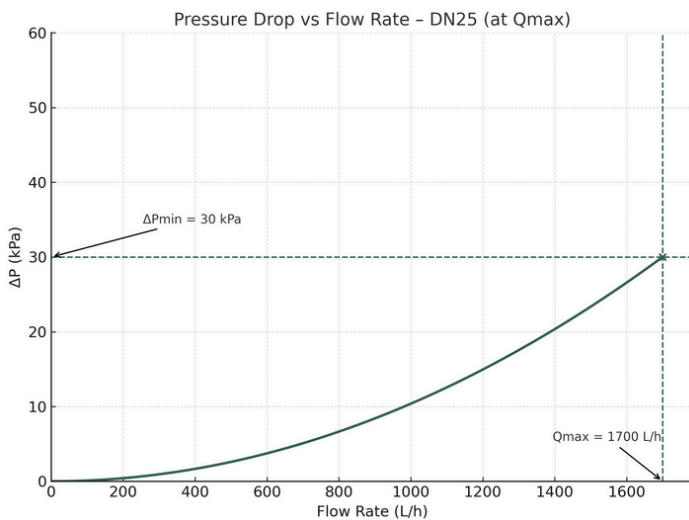

BRQ-9000SF DN 32

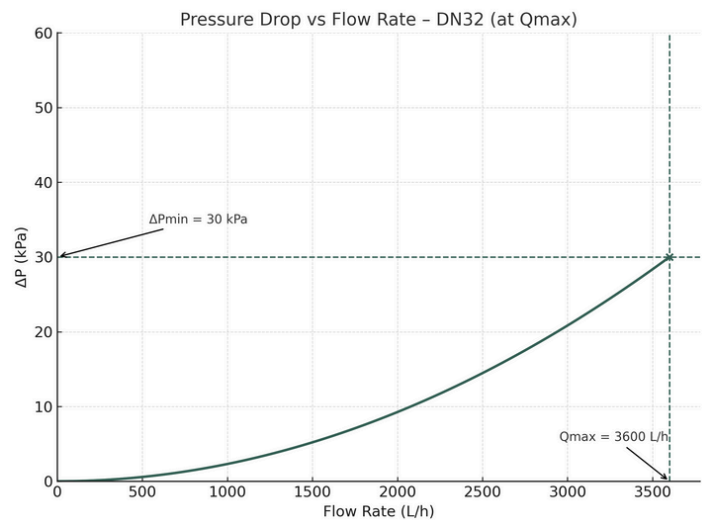



Functional Principle

BRQ-9000SF PICV combines three integrated functions in a single valve:

1. Presetting adjusting mechanism

A dial for setting the maximum volumetric flow.

Ensures the flow does not exceed the preset value regardless of system variations.

2. Differential pressure controller

Maintains a constant differential pressure (ΔP) across the control valve (P1-P2).

Guarantees stable and accurate flow even with changes in pump speed or other valves.

3. Modulating control valve

Provides precise regulation of the volumetric flow.

Operated by an actuator to control room/zone temperature.

4. Pressure test plugs (P/T plugs)

Allow direct measurement of pressure and temperature at the valve.

5. Actuator

Receives control signals and adjusts the valve opening to match the required flow.

6. Energy Efficiency

Reduces pumping energy by maintaining stable flow under varying system pressures.

Contributes to overall system optimization and lower operating costs.

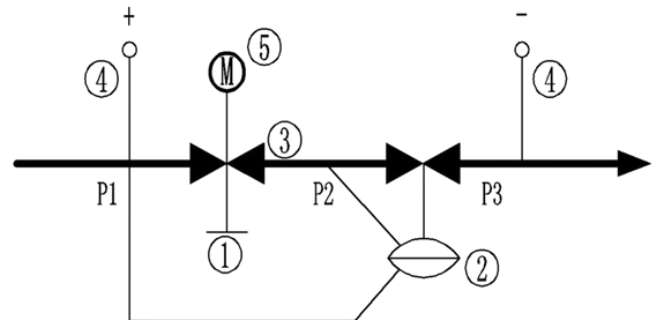

The main components of the valve are:

- ① Presetting adjusting mechanism
- ② Differential pressure controller
- ③ Modulating control valve
- ④ Pressure test plugs (P/T plugs)
- ⑤ Actuator



Installation



- Preferably mount the valves at the return, as the temperature is lower there and the strain on the stem sealing gland is lower.
- Mount a dirt filter or dirt trap before the valve to ensure proper functioning, and a long service life of the valve.
- Remove dirt, welding beads, etc. from the valves and pipes.
- Do not insulate the actuator bracket, as air circulation must be ensured.
- The valve should not be installed in places prone to knock, and impact and vibration, the ambient temperature is 2°C to 50°C. In addition, it should not be installed in an environment with steam, water jet or water dripping.

Mounting positions

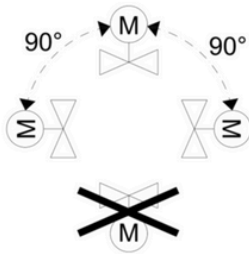

Medium flow direction



Installation must follow the medium flow direction on the valve body.

Commissioning & Operation Instructions



- The valve may only be operated after ensuring that both the actuator and valve are correctly assembled.
- During flushing or pressure testing of the system, the valve must remain open, as sudden pressure impacts can damage closed valves.
- The maximum differential pressure (ΔP_{max}) across the valve's control path must not exceed 400 kPa. Exceeding this limit may cause damage to the valve when in the closed position.
- Commissioning must always be carried out with the actuator properly installed and securely fitted.
- Ensure that the actuator stem and valve stem remain firmly connected in all operating positions.

Valve Operation:

Valve Stem Position	Valve Opening Status
Retracts	Closes
Extends	Opens

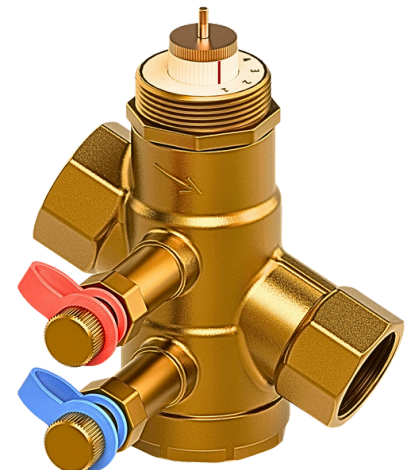



Maintenance

When carrying out service work on the valve or actuator, always follow these safety instructions:

- Switch off the pump and disconnect the power supply.
- Close the shut-off valves in the piping network.
- Fully release pressure from the piping system and allow the pipes to cool down completely.
- Disconnect electrical connections only if necessary. 

Before proceeding, ensure that the actuator is removed correctly. Perform the required valve maintenance, then reinstall the actuator properly to guarantee safe commissioning of the system.

Sealing Gland

- Stem seals can be replaced without removing the valve body, provided there is no damage or wear on the stem surface.
- If the stem itself is found to be damaged, the entire valve must be replaced.

Disposal

- Due to the variety of materials used in the valve, it must be disassembled before disposal.
- Certain components may require special handling in compliance with environmental regulations or ecological best practices.
- Disposal must always follow local legislation and current environmental standards.

⚠ Safety Precautions

- Do not operate the valve outside the rated pressure and temperature limits.
- Avoid hammering or applying mechanical stress on the valve body during installation.
- Do not operate the valve without a properly fitted actuator (for PICV applications).

Spare Parts

- Stem seals are available as spare parts and can be replaced without removing the valve body.
- Compatible actuators (On/Off or Modulating) are available upon request.
- Only original spare parts should be used to maintain performance and warranty validity.



BARIQ Valves Manufacturer
مصنع صمامات بارق للصناعة

رؤية
2030
المملكة العربية السعودية
KINGDOM OF SAUDI ARABIA



BRQ-ACT-13 Smart Actuator for PICV



Features – BRQ-ACT-13 Actuator

- **Operating Voltage:** 24 VAC/DC, suitable for BMS integration
- **Control Signal:** Proportional 0–10 V DC input
- **Failsafe Function:** Built-in internal energy storage ensures automatic return to safe position during power failure
- **Position Feedback:** LC display with valve position indication and error codes
- **Manual Override:** Integrated manual adjustment for installation and maintenance
- **Compact Design:** Robust housing with IP54 protection rating
- **Response Time:** Very short reaction time with high positioning accuracy
- **Actuating Force:** 125 N (other forces available upon request)
- **Stroke Speed:** 15 s/mm or 30 s/mm (depending on configuration)
- **Connection:** Plug-in connecting cable for quick installation
- **Mounting Position:** 360° installation flexibility
- **Energy Efficiency:** Low power consumption, maintenance-free operation
- **Reliability:** Self-locking gear in all positions, long service life
- **Safety:** Automatic motor shutdown at end positions (valve path recognition)
- **Optional:** NFC configuration and app support (iOS/Android) for parameter setting
- **Compliance:** CE, ISO, and applicable international standards

Product Overview

The BRQ-ACT-13 is a 24V proportional failsafe actuator designed for precise and energy-efficient control of BRQ PICV valves in heating and cooling systems.

It operates via a 0–10 VDC control signal from a DDC system or thermostat and is equipped with an LCD display for valve position, control voltage, and error indication.

The actuator features a pluggable cable connection, manual override for maintenance, and provides feedback signals for accurate monitoring of valve status.

With its compact design and compatibility with BRQ valves, the BRQ-ACT-13 ensures reliable performance and easy installation in building automation systems.





BRQ-ACT-13 Actuator

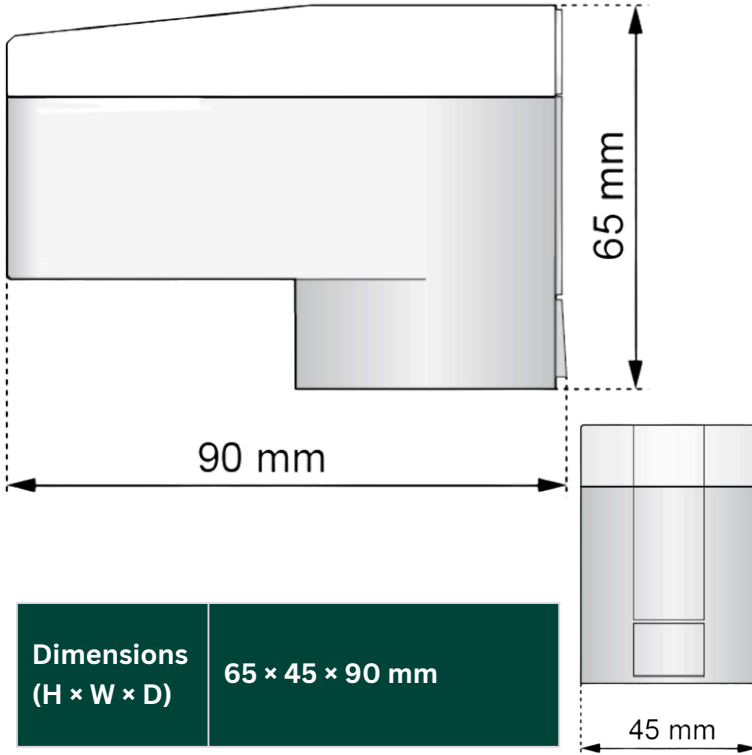

BRQ-ACT-13 Actuator Specification

Parameter	Specification
Application	Suitable for PICV BRQ-9000SF (DN15–DN32)
Control Type	Modulating (0–10 V DC)
Power Supply	24 V AC/DC ±10%
Power Consumption	1.1 W (DC) / 2.1 VA (AC)
Actuating Force	125 N (optimized for DN15–DN32 PICV)
Stroke	Model BRQ-ACT-13 supports a configurable travel limit, enabling a single actuator to operate BRQ-9000SF valves DN15–DN32. Set effective stroke to 2.5 mm (DN15–DN20), 5.0 mm (DN25), and 6.0 mm (DN32). Over-travel protection and commissioning calibration are required after setting the stroke limit
Actuating Time	2.5 mm/min (approx. 20–25 sec full stroke)
Failsafe Function	Optional failsafe, park position adjustable
Control Signal	0–10 V DC / 2–10 V DC (selectable)
Feedback Signal	0–10 V DC (position feedback)
Manual Override	Yes, by handwheel (in case of power loss)
Ambient Temperature	0 ... +50 °C
Fluid Temperature Range	0 ... +90 °C
Protection Class	IP 54
Application	Suitable for PICV BRQ-9000SF (DN15–DN32)
Control Type	Modulating (0–10 V DC)
Power Supply	24 V AC/DC ±10%
Power Consumption	1.1 W (DC) / 2.1 VA (AC)

Item	Specification
Casing Material	Polyamide
Casing Color	Signal white (RAL 9003)
Casing Cover Material	Polycarbonate
Casing Cover Color	Transparent
Cable Type	4 × 0.22 mm ² PVC (Optional: 3 × 0.22 mm ² PVC)
Cable Color	White
Cable Length	1 m
Weight (with 1 m cable)	155 g
Surge Strength (EN 60730-1)	1 kV



BRQ-ACT-13 Actuator

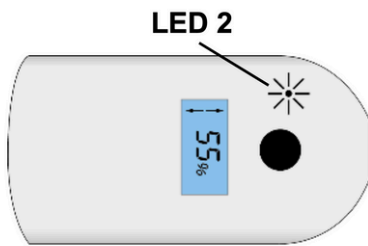
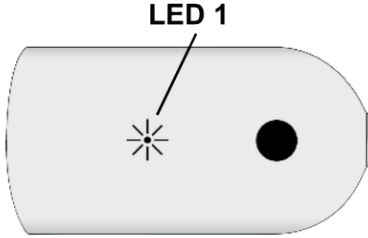

LED 1 - Signal	Meaning
Green flashing	Initialization
Red	Error

LED 2	Description
Green (flashes)	Failsafe operation, parking position is approached
Green	Device ready
Orange	Ready for operation, battery is charging
Red	Error

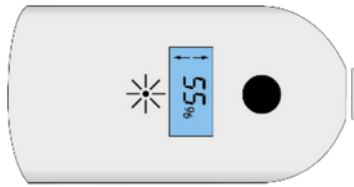

The LC display of the BRQ-ACT-13 Motoric Valve Drive 6: 24 V Proportional Failsafe alternately shows the setting position and the applied control voltage.

In case of a control requirement, the current driving direction is indicated on the LC display by means of an arrow.

In case of an error, the corresponding error code is shown, and the error is indicated by a steadily illuminated LED.

Error Code

Error Code	Description	Error Correction
E7	Blockage during initialization run at non-permitted position	1. Disconnect actuator from voltage supply 2. Move the actuator shaft with the manual adjuster out of the end position 3. Re-initialize after switching on the voltage supply again <i>If the fault occurs repeatedly, contact customer service.</i>
E8	Motor current too low	1. Re-initialize by switching the actuator off and on again <i>If the fault cannot be rectified after max. 3 attempts, contact customer service.</i>
E9	Driving too long in one direction	1. Re-initialize by switching the actuator off and on again <i>If the fault cannot be rectified after max. 3 attempts, contact customer service.</i>



BRQ-ACT-13 Actuator Installation

Attention



Mounting the actuator while the valve pressure plate is extended may cause damage to the actuator.

Always install the actuator when the valve pressure plate is fully retracted (manually or electrically).

Installation Steps

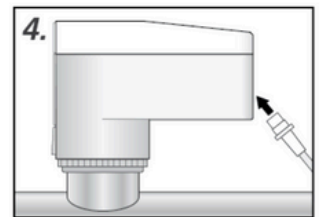
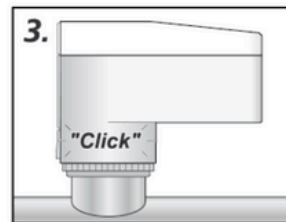
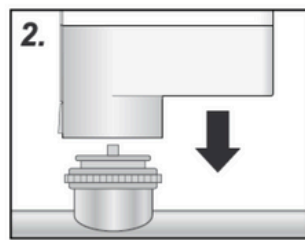
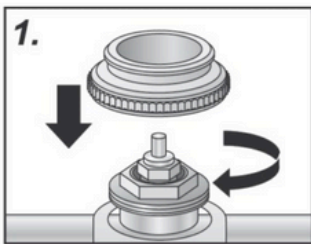

For installing the BRQ-ACT-13 Actuator (24 V system), the following maximum cable lengths are recommended:

Connection Line

Cable Type	Section	Max. Length
Standard DDC line	0.22 mm ²	20 m
J-Y(ST)Y	0.8 mm ²	45 m
NYM / NYIF	1.5 mm ²	136 m

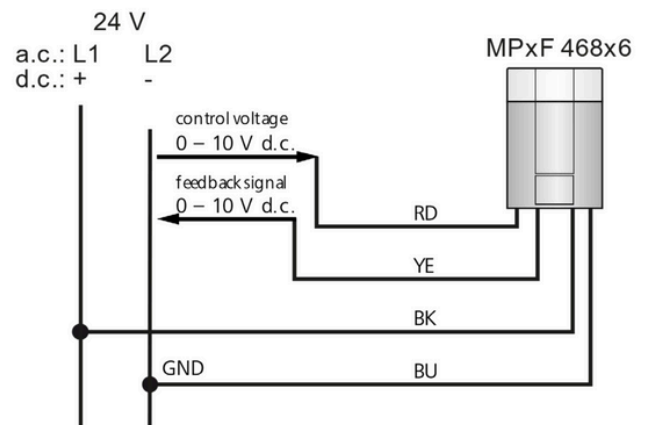

Transformer / Power Supply Unit

- A safety isolating transformer according to EN 61558-2-6, or a switching power supply according to EN 61558-2-16, must always be used.
- The dimensioning of the transformer or switching power supply should be based on the maximum inrush current capacity of the BRQ-ACT-13 actuators.